

# Swift Blanking Dies



DIE MASTERS INC

Lean Manufacturing Solutions for Metal Stamping

*Swift* Blanking Dies are the perfect solution when your turret press and laser cutting systems just can't keep up. Produce 50 to 10,000 parts per month with shorter setup times, less waste, and easy maintenance. Swift Blanking Dies have been saving our customers **TIME**, **SPACE** and **MONEY** for years!

## Save TIME

Swift Blanking Dies are used in combination with a Master Die Set fit to your press. Once installed, any Swift die can be quickly loaded and unloaded from your press. A single stroke of the press can produce one or multiple parts. Also, each new Swift die can be ready to install in 1 to 3 weeks.

16" X 16" Die  
Makes .125" X 7" X 8" Steel part

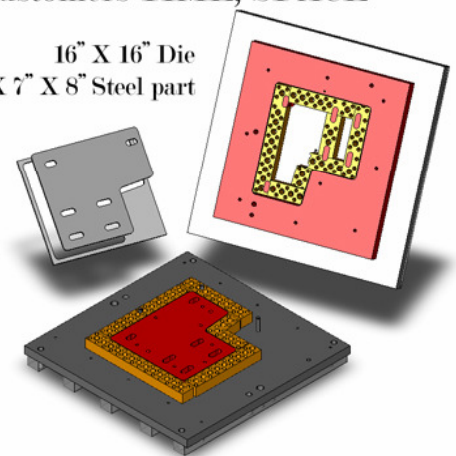

## Save SPACE

Swift Blanking Dies are true Lean Manufacturing systems. Easily store just the tool, not the parts. If you need 100 parts ran this week, go ahead. Place the Swift die back on the shelf and select the next one. You will even have less scrap in the process.

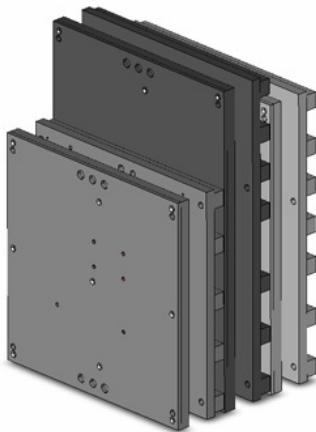

3 dies racked  
less than 12" wide

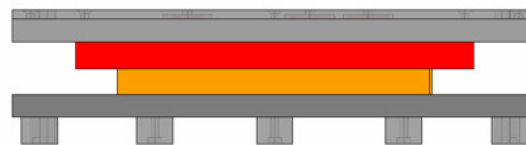

3.750" Shut Height

## Save MONEY

Swift Blanking Dies are much less expensive than class A blanking dies. Each Swift die you own will save you money in time per part and in quick tool changes. Simple maintenance and easy sharpening saves you money where it counts.

## How They Work

*Swift* Blanking Dies use 5/8" Mic-6 aluminum shoes with 1/2" A2 die sections. Urethane is used to strip the parts off the punches, keeping unnecessary weight down. Stamp parts out of blanks, strip or coil steel or aluminum. Maintenance couldn't be easier, steel parallels amongst the aluminum allows for the Swift dies to be sharpened on a standard surface grinder without removing the die sections or punches.

Send some prints and monthly production quantities to DMI for your **FREE QUOTE** and see if your company can benefit from the **TIME**, **SPACE**, and **MONEY** saving potential of Swift Blanking Dies.



DMI | Die Masters Inc.  
2305 SE Palmsblad Unit C  
Gresham, Oregon 97080

P: 503.667.2620

F: 503.661.4033

Swift@diemasters.com  
www.diemasters.com